

Proudly Made in the USA

# ARCTIC

## COMPRESSOR

“The Simple Choice”

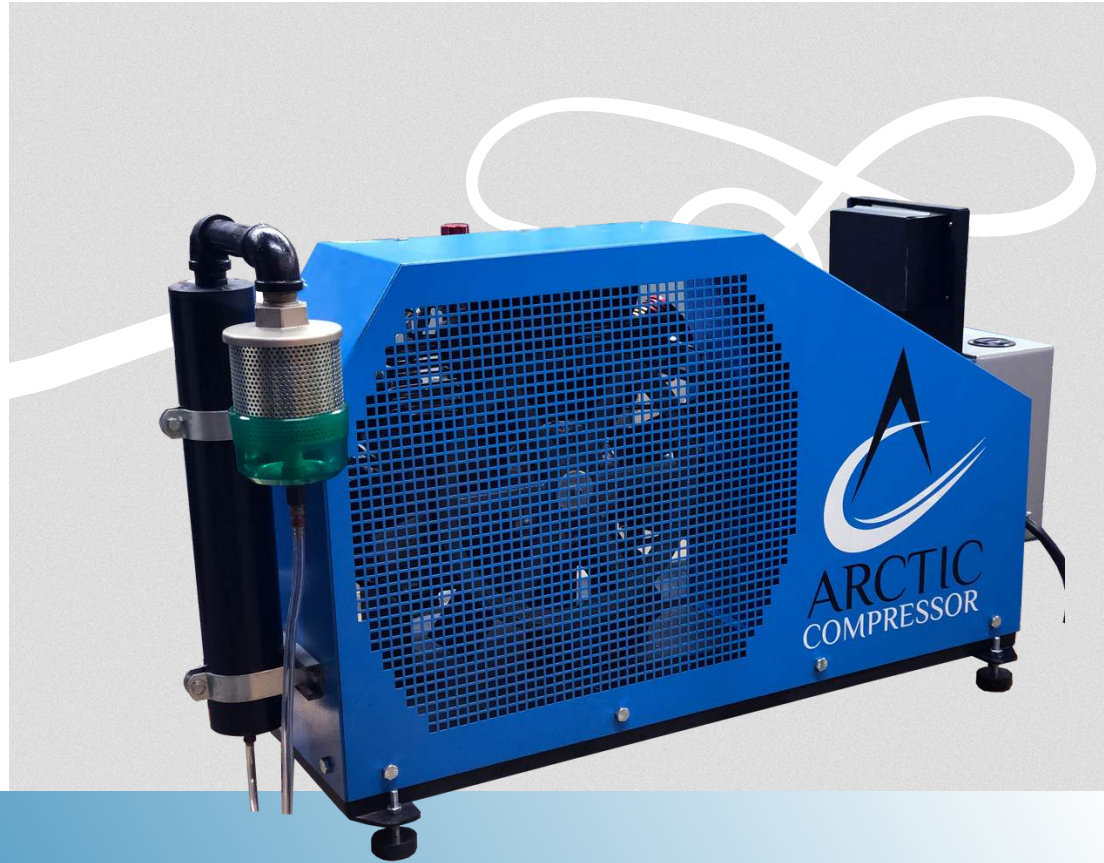
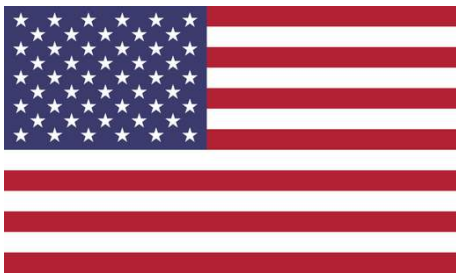
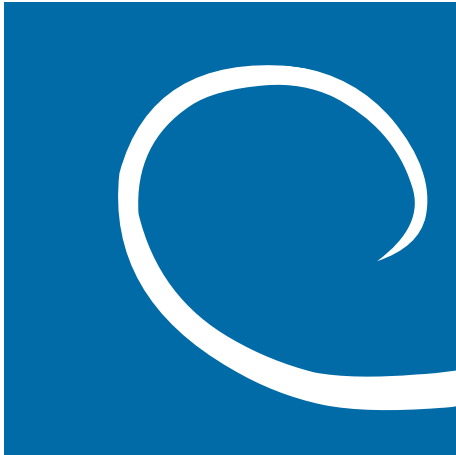

**OPEN FRAME  
1000 & 1500  
SERIES  
COMPRESSORS**

# OPEN FRAME 1000 & 1500 SERIES COMPRESSORS

| Open Frame Compressors    |             |             |             |
|---------------------------|-------------|-------------|-------------|
| Model                     | O3-7.5      | O3-7.5      | O4-10       |
| HP                        | 7.5         | 7.5         | 10          |
| Max Pressure (PSI)        | 5000        | 6000        | 6000        |
| CFM                       | 9           | 8           | 14          |
| Compression Stages        | 3           | 3           | 4           |
| Weight (Lbs)              | 320         | 320         | 410         |
| Filtration Units (Cu. Ft) | 9,800       | 9,800       | 9,800       |
| Lubrication Type          | Splash      | Splash      | Splash      |
| Oil Capacity              | 3 Qt        | 3 Qt        | 3 Qt        |
| Low Oil Shutdown          | Optional    | Optional    | Optional    |
| Electric Motor Phase      | Single or 3 | Single or 3 | Single or 3 |

## FEATURES:

- Air cooled 3 or 4 stage proprietary block
- Relief valves on all stages
- Aluminum intercoolers
- Stainless steel aftercooler
- High velocity, 10 blade fan
- Final pressure gauge
- Rubber vibration isolation

## OPTIONS:

- Magnetic starter with stop/start switch
- Hour meter
- Automatic drain system
- Automatic high pressure shut down
- 16,000 Cu. Ft. filtration capacity
- 24,000 Cu. Ft. filtration capacity
- 480v 3-phase

## PURIFICATION:

9,800 Cu. Ft. at 80 degrees Fahrenheit filtration system designed to provide C.G.A. grade "E" air. The system uses a dryer bed to remove water in excess of dew point -65 degrees (NFPA 1 500 standard) Activated charcoal and a carbon monoxide catalyst remove remaining contaminants to provide CGA Grade "E" breathing air. Additional filtration capacity can be added for high volume users.



# TECHNICAL INFORMATION

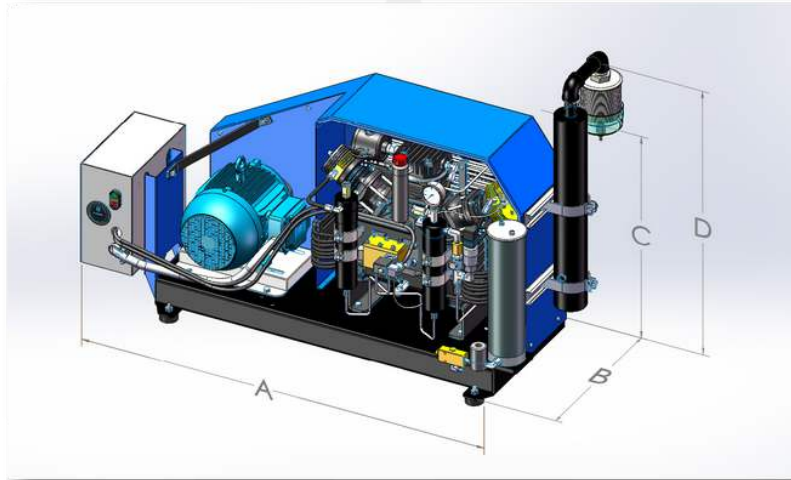

## DIMENSIONS

|   | 3 STAGE | 4 STAGE |
|---|---------|---------|
| A | 54"     | 54"     |
| B | 20"     | 20"     |
| C | 26"     | 30"     |
| D | 34"     | 34"     |

Install minimum 6" from wall

All Arctic Compressors include an 8' electrical cord and plug

## REQUIRED SERVICE AMPERAGE

|        | 208/240V     |             | 480V Three Phase |
|--------|--------------|-------------|------------------|
|        | Single Phase | Three Phase |                  |
| 7.5 HP | 50 Amp       | 30 Amp      | 20 Amp           |
| 10 HP  | 50 Amp       | 30 Amp      | 20 Amp           |

## ELECTRICAL CONNECTION

|       | 208/240V     |             | 480V Three Phase |
|-------|--------------|-------------|------------------|
|       | Single Phase | Three Phase |                  |
| 7.5HP | NEMA 6-50    | NEMA L15-30 | NEMA L16-20      |
| 10HP  | NEMA 6-50    | NEMA L15-30 | NEMA L16-20      |

# THE SIMPLE CHOICE BENEFITS

**SIMPLE VALUE** / High quality American-made equipment, affordably priced

**SIMPLE OPERATION** / Minimizes operator training requirements

**SIMPLE MAINTENANCE** / Designed for easy maintenance, reducing overall cost of ownership

**SIMPLE SERVICE** / Nationwide distributor + service network providing fast local service

*With benefits like these,  
it's easy to see why  
Arctic Compressor is  
"The Simple Choice"*



**Proudly Made  
in the USA**



69 N 28th St. Suite #500 Superior, WI 54880  
(715) 718-3065 / [info@arcticcompressor.com](mailto:info@arcticcompressor.com)

[www.ArcticCompressor.com](http://www.ArcticCompressor.com)